

MODELS PSR 5" & ABOVE INSTALLATION INSTRUCTIONS

100% and 200% MODELS SIMILAR

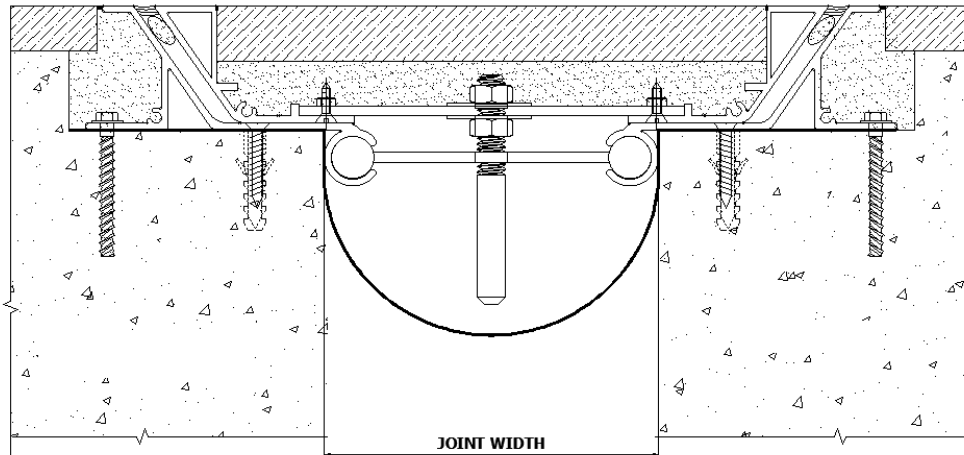

IMPORTANT INFORMATION

Prior to the commencement of Installation, all materials MUST be inspected for Damage. Any damage must be reported to PINNACLE SOLUTIONS, as soon as possible, so that replacement materials may be furnished without delay.

All work must be completed as per Architect's Approved "Shop Drawings", and in accordance with these Installation Instructions. When installation is complete, all materials must be protected from damage until the Architect's FINAL INSPECTION.

All materials should be arranged in the order that they are to be installed. All hardware required for each portion of the work should be placed with the appropriate materials.

Please review all Approved Shop Drawings and this Document to familiarize yourself with all the details and components of this assembly.

IMPORTANT:

READ THROUGH ALL INSTRUCTIONS PRIOR TO STARTING INSTALLATION

GENERAL NOTES

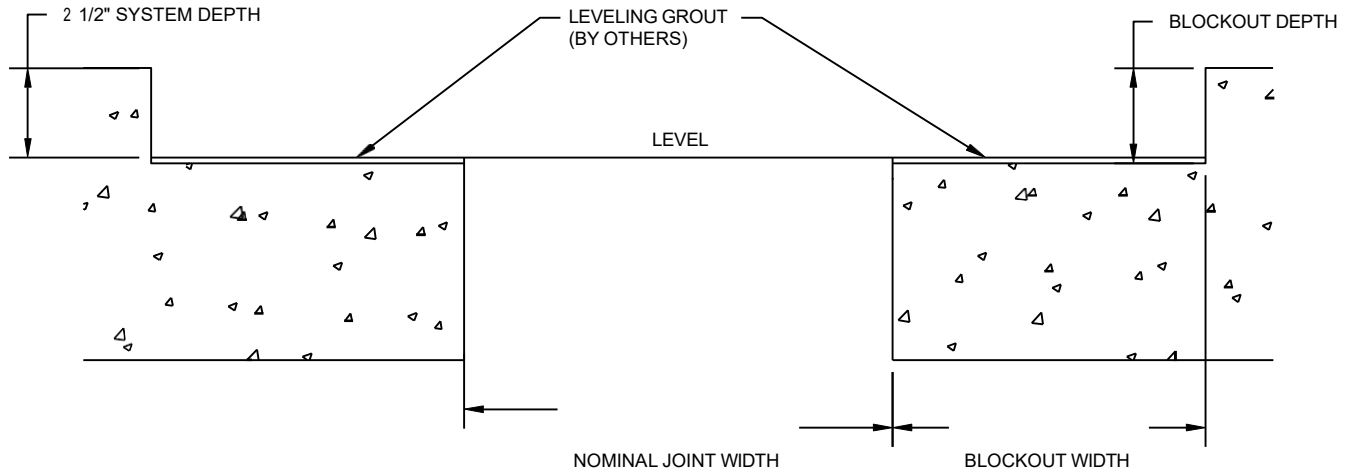

- 1.) Before beginning installation of these joint covers, review the layouts for the various runs of joint cover as detailed on the approved PS shop drawings.
- 2.) The "PSR" series joint covers must be securely mounted to structurally sound substrates. Repair all cracks or spawled areas of the concrete in the blockouts and in the deck adjacent to the blockout.
- 3.) The blockouts in which the covers are to be mounted must be **flat, level and parallel**. The blockout depth should be made deeper than the actual system depth and self-leveling grout should be used to set the final depth, and to provide a smooth, flat finish. **The base of the blockout must be flat (along the length of the joint) to within $\pm 1/16$ " and level (across the joint) to within $\pm 1/16$ ".**
- 4.) The blockout width shown on the PS shop drawings is a minimum width dimension. The blockout may be made wider to allow for greater installation tolerance.
- 5.) The surface of the blockouts must be clean and free from any loose dust, dirt, debris and oils that would affect the installation of the covers.
- 6.) It is possible that the expansion/seismic joint may have experienced some amount of movement at the time of installation. For proper installation of the "PSR" covers, the joint width **must be within $\pm 1/4$ " of nominal**. If the joint width at the time of installation is not within this tolerance, please contact the factory as some adjustments to the key installation dimensions may be required. These instructions assume that the nominal joint is within tolerance.
- 7.) Coordinate installation of cover with installation of fire barrier systems and vapor barrier membrane when required.

IMPORTANT: Concrete will curl the center-plate of this system unless you take proper measures to prevent it.

Selection of the proper concrete mix is essential. Talk to your local Concrete supply Engineer and discuss this special application and get their recommendation(s) for the mix that will prevent excessive curling of the center-plate/pan. (They know concrete, your local practices and weather conditions.)

Their recommendations may include a low water-to-cement ratio; changing the aggregate, adjusting the cement-to-fly ash ratio; longer cure time; controlling shrinkage with an admixture; moist curing, ect.

All such recommendations should be coordinated with the Architect to ensure the integrity of the specification is maintained.

EXTERIOR INSTALLATION of this expansion joint cover system requires yet more care and in addition to any/all of the above possible recommendations from your Concrete Engineer, moist curing has been found to be essential to a successful installation.

STEP 1

BEGIN BASE FRAME INSTALLATION



Note: Proper installation of the "PSR" covers is dependent upon the proper location of the Base Frames. For the pan assembly to fit and function properly between the Frames, the Frames must be anchored parallel to the joint and to one another. They must be located at the proper distance for the edge of the joint and the exposed surface dimension must be maintained within a tolerance of $\pm 1/8$ ". The exposed surface must also be centered over the joint to within $\pm 1/8$ ".

The Frame Location and Exposed Surface and Joint Width dimensions are shown on the PS shop drawings.



(Fig. 1A)



(Fig. 1B)

1.1) In the blockout on one side of the joint, measure and mark the bottom of the block out at the Frame location dimension. Strike a chalk line at this location, along the full length of the run. (See Fig 1A & 1B)

1.2) Beginning near the center of the run and working towards each end, position the first length of Frame along the Frame location line.

1.3) Using the Frame as a template, drill the holes for the PS supplied anchors. (Follow the drilling instructions provided by the anchor bolt manufacturer.) (See Fig. 1C)

1.4) Remove the Frame and clean the holes. Reposition the Frame and anchor the Frame into the blockout with the PS supplied anchors. (Follow the anchor manufacturer's installation instructions.)



(Fig. 1C)

STEP 2

CONTINUE BASE FRAME INSTALLATION



(Fig. 2A)

(Fig. 2B)

Note: To assist in maintaining the alignment of the exposed top edge of Base Frames alignment pins are to be placed in the Frame sections prior to installation. (See Fig. 2A & 2B)

2.1) Insert grooved end of the alignment pins, approximately 1/2 of its length, into each of the extrusion bosses of the next length of Base Frame.

2.2) Position the adjacent lengths of Frame into the blockout and insert the alignment pins into the extrusion bosses of the previous Frame.



(Fig. 2C)

2.3) Following the instruction from Step 1, position, drill and anchor each additional length of Base Frame for this side of the joint. (See Fig. 2C)

Note: As you approach each end of the run, the last lengths of Frame may have to be cut to the appropriate length.

STEP 3

INSTALL OPPOSITE BASE FRAME



(Fig. 3A)



(Fig. 3B)

- 3.1) Beginning again near the center of the run and working towards each end, position the first length of Base Frame in the opposite blockout.
- 3.2) Measuring off the top edge of the initial anchored length of Base Frame, position this length of Frame so that the exposed surface dimension is maintained. Make sure that the Frame is equal distance or parallel to the initial Frame, over the full length. (See Fig. 3A)
- 3.3) Using the Frame as a template, drill the holes for the PS supplied anchors. (Follow the drilling instructions provided by the anchor manufacturer.)
- 3.4) Remove the Frame and clean the holes. Reposition the Frame and anchor the Frame into the blockout with the PS supplied anchors. (Follow the anchor manufacturer's installation instructions.) (See Fig. 3B)
- 3.5) Insert grooved end of the alignment pins, approximately 1/2 of its length into the next length of Frame and position it into the blockout. (See Fig. 2A & 2B on page 4)
- 3.6) Again, position the Frame parallel to the Frame in the opposite blockout and anchor according to the previous instructions.
- 3.7) Repeat and install the remaining Frames for the entire length of the run.

STEP 4

BEGIN INSTALLATION OF TURN BAR FRAMES

Note: The Turn Bar Frames are to be located so that they nest over the corner of the slab. Due to irregularities in the edge of the slab or due to the proximity of the Base Frame, the Turn Bar Frame may cantilever out from the face of the slab by up to 1/4".

4.1) Beginning again near the center of the run and working towards each end, position the first length of Turn Bar Frame on the corner of the slab.
(See Fig. 4A)



(Fig. 4A)



(Fig. 4B)

4.2) Using the Frame as a template, drill the holes for the PS supplied anchors. (Follow the drilling instructions provided by the anchor manufacturer.)

4.3) Remove the Frame and clean the holes. Reposition the Frame and anchor the Frame into the blockout with the PS supplied anchors. (Follow the anchor manufacturer's installation instructions.)
(See Fig. 4B)

4.4) Position, drill and install the Turn Bar Frame at the opposite side of the joint. (Note: It is recommended that the Turn Bar Frames be installed in pairs, one at each side of the joint, to facilitate installation of the Turn Bar Assemblies as indicated in Step 5.) (See Fig. 4C)



(Fig. 4C)

STEP 5

BEGIN TO INSTALL TURN BARS

*Note: MODELS 5" - 7" See Instructions below
MODELS 8" & Above See Instructions on page 8

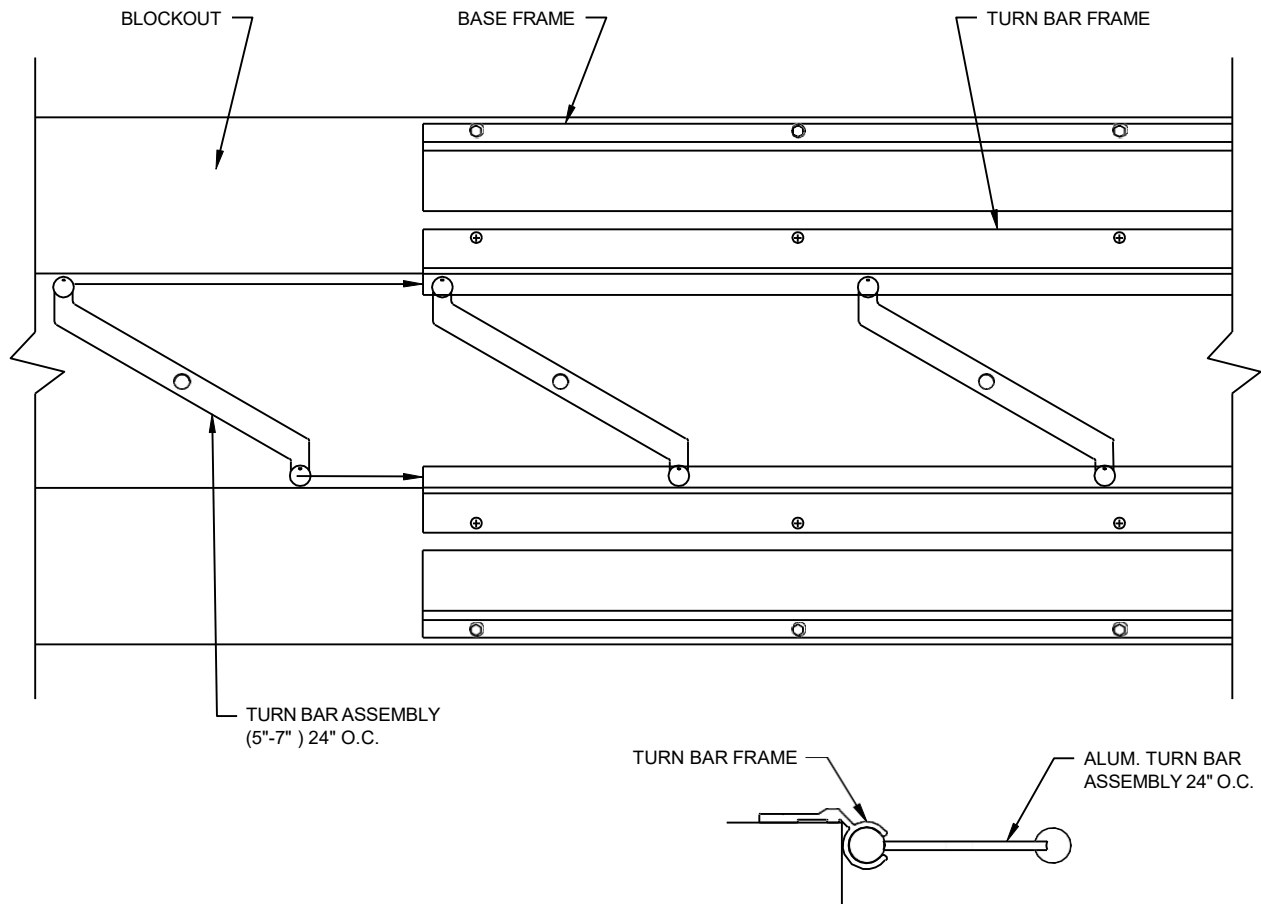

END VIEW

MODELS 5" - 7"

Note: The Turn Bar Assemblies 5" - 7" 100% & 200% models are spaced at approx. 24" o.c., (5) assemblies per 10'-0" length or (10) per 20'-0" length of Frames.

5.1) With the first pair of Turn bar Frames installed, insert the first Turn bar assembly into the Frames. Note the orientation of the Turn Bars as shown in the detail above. The bent angle of the turn bar extrusion and ball pins are to face outward, towards the Frames, so that the turn bar aluminum tube does not contact the Frames.

5.2) Place the ball, at one end of the assembly, into the appropriate Turn Bar Frame and slide inward until the ball at the opposite end can be inserted into the opposite Turn Bar Frame.

5.3) Repeat the inserting procedure for the remaining number of bars as required for the length of Frame.

5.4) Continue with installation of the adjacent lengths of Turn Bar Frame, inserting the Turn Bar Assemblies with each pair as they are installed.

Note: At an end condition, the Turn Bars may have to be inserted before the final length of Frame is anchored.

STEP 5 Con't.

BEGIN TO INSTALL TURN BARS

MODELS 8" & Above See Instructions below

MODELS 8" & Above

Note: Turn Bar Assemblies are spaced per 10'-0" length of Frames.

5.1) Measure the center pan centerpost holes and mark the centerline locations on the Turn Bar Frame. (See Fig. 5A & 5B)
See the drafting details for the on center spacing.



(Fig. 5A)



(Fig. 5B)

5.2) Insert the first Turn Bar Assembly into the Frames. Note the orientation of the Turn Bars as shown in the picture. The bent angle of the ball pins are to face outward, towards the Frames, so that the channel does not contact the Frames. The wide, flat portion of the channel should be up with the short legs facing down. (See Fig. 5C)

5.3) Place the ball, at one end of the assembly, into the appropriate Turn Bar Frame and slide inward until the ball at the opposite end can be inserted into the opposite Turn Bar Frame.

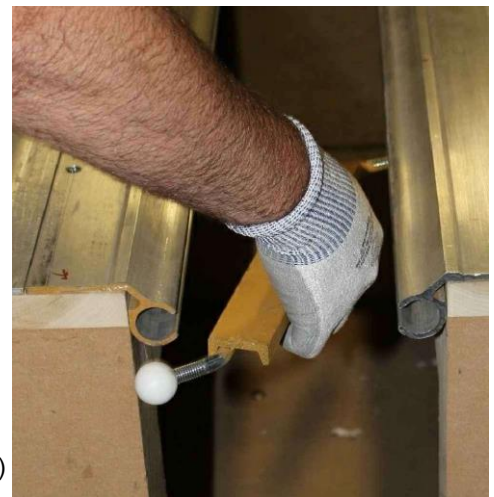

(Fig. 5C)

STEP 5 Con't

BEGIN TO INSTALL TURN BARS



(Fig. 5D)

5.4) Repeat the inserting procedure for the remaining number of bars as required for the length of Frame. Align the center hole of each Turn Bar with the measured on center locations on the Turn Bar Frames. (See Fig. 5D)

5.5) Continue with installation of the adjacent lengths of Turn Bar Frame, inserting the Turn bar Assemblies to the measured on center locations with each pair as they are installed.

Note: At an end condition, the Turn Bars may have to be inserted before the final length of Frame is anchored

STEP 6

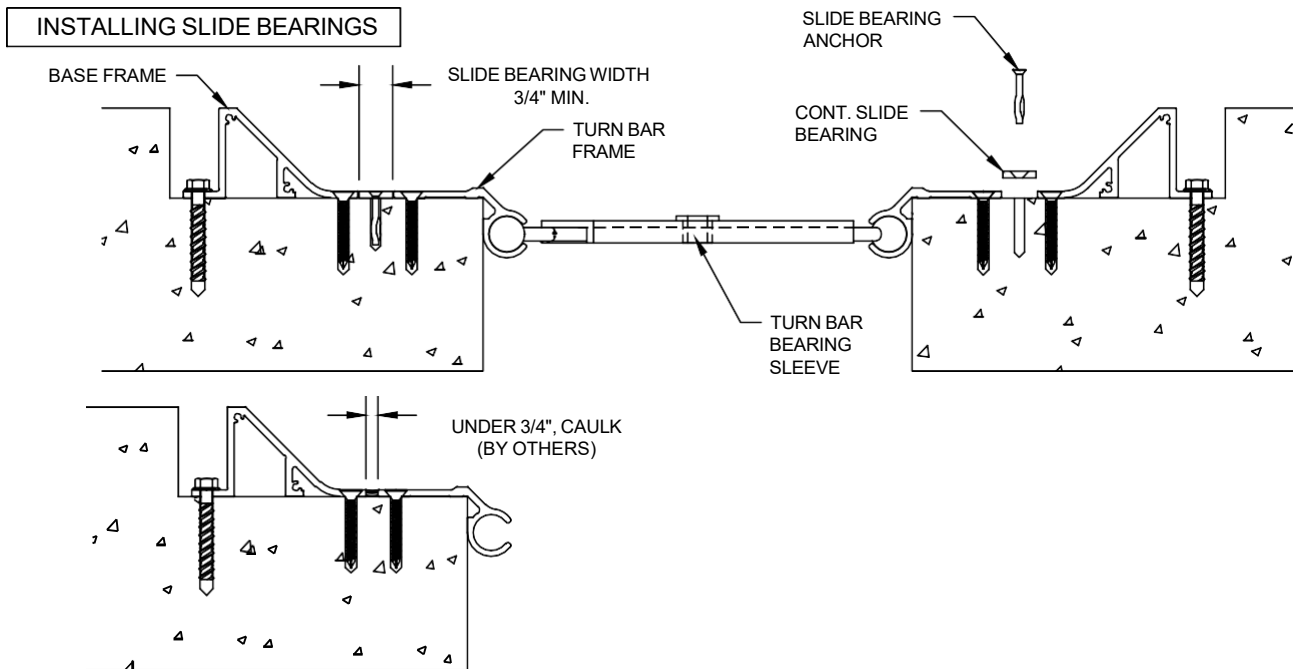

Note: The Slide Bearings are used to prevent the pan bearings from dropping into the space between Frames during seismic movement and causing damage. When the space between Frames is less than 3/4" wide, the space is to be filled level with caulking (by others). **Refer to shop drawing details for slide bearing use.

- 6.1) Models with Slide Bearings position the first length of continuous slide bearing into the space between the Base Frame and Turn Bar Frame. Models with seven (7) Slide Bearing pieces in a 10' run, starting at one end of the Base Frame position the first piece so that it butts against the lower leg of the base frame. Space the remaining Slide Bearing pieces (6 of them) evenly in the 10' length, at approx. 1'-7 1/2" O.C..
- 6.2) Using the Slide Bearing as a template, mark the hole locations for the bearing anchors, then remove the Slide Bearing.
- 6.3) Drill the holes for the appropriate PS supplied anchors. (Drill the holes per the anchor manufacturer's instructions.)
- 6.4) Place the Slide Bearing back into position and anchor to the slab.
- 6.5) Repeat for the remaining Slide Bearing lengths that are required for each side of the joint.

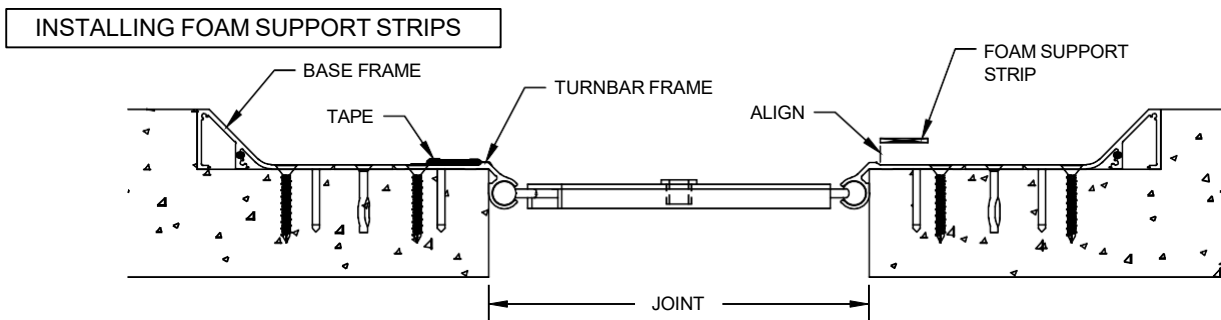

Note: Foam support strips are 1 1/2" wide by 3/16" thick strips of styrofoam that have been provided by PS. These strips are to be placed on top of the Turnbar Frames continuously along the full length of the run. These strips will support the underside of the center pans to prevent bowing of the Pan as the concrete is poured. Used in pan widths of 27" and larger.

- 6.6) Position the lengths of continuous foam support strip so the inside edge aligns with the raised portion of the Turnbar Frame. Place foam strips along each side of the joint, for the full length of the run.
- 6.7) Use several short lengths of duct tape to hold each strip in place

STEP 7

CENTER PAN ASSEMBLY AND INSTALLATION



(Fig. 7A)

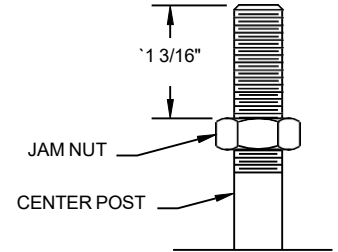

Note: Center Pan Assemblies are supplied in typical 10'-0" lengths. The holes for the Center Posts will be located and drilled in the factory.

- 7.1) Place a Jam Nut onto each Center Post and thread on until the nut is approximately 1 3/16" in from the end.
- 7.2) Place a large diameter Flat Washer over the Jam Nut and insert the threaded end of the Center Post up through the hole from the underside of the Pan.
- 7.3) From the top side of the Pan, place a large diameter Flat Washer and Jam Nut onto the Center Post. (See Fig. 7A)
- 7.4) Tighten the Jam Nut against the Pan and Flat Washer.



(Fig. 7C)

- 7.5) Beginning near the center of the run, position the first Pan along side the joint.
- 7.6) Apply a heavy bead of grease to the inside of the bearing sleeve of each Turn Bar.
- 7.7) Hold the Pan over the joint. Align the Center Posts with the Turn Bars. Seat the Pan onto the Frames with the Center Posts positioned through the sleeve bearings of the Turn Bars. (See Fig. 7C)

STEP 8

PAN SPLICING

Note: Center Pan Assemblies are supplied in typical 10'-0" lengths. Each pan is to be field spliced to the adjacent Pans to maintain alignment. A minimum 1/16" gap must be maintained between Pan Assemblies to allow for thermal expansion.

- 8.1) Place the next Pan Assembly onto the Frames as instructed in Step 7.
- 8.2) Slide the Pan along the Frames until the ends of the Pans butt together. Separate slightly to maintain a minimum 1/16" gap.
- 8.3) Adjust the Pans across the joint so that the top corners of the Pan are in alignment.
- 8.4) Place a strip of masking tape or duct tape on top of the Pans, over the butt joint, for the full width of the Pan.
- 8.5) Center one of the PS supplied splice plates over the butt joint and attach to the Pan using the supplied self-drilling tek screws. Note: Maintain the minimum 1/16" gap at the butt joint.

STEP 9

COMPLETING THE INSTALLATION

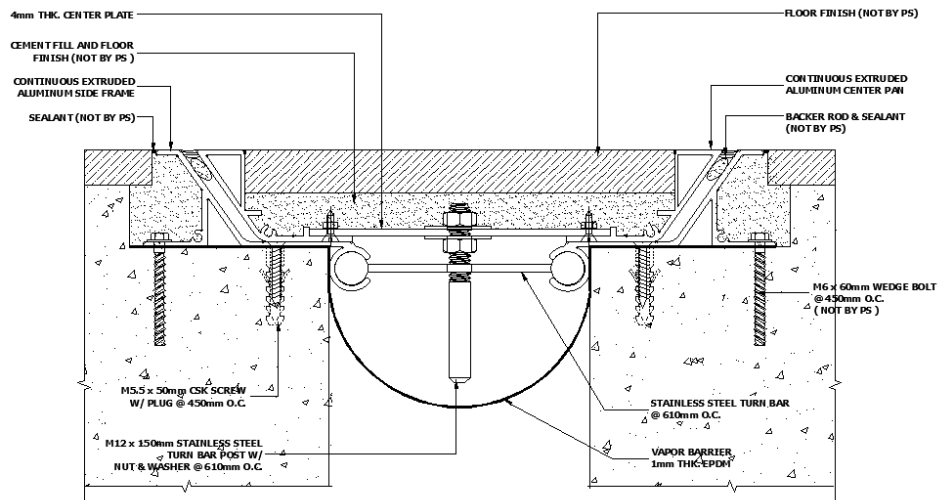

Note: With the joint cover assemblies installed for the full length of the run, the following steps will complete the installation. The steps do not necessarily have to be completed in the order shown.

9.1 Place the PS supplied oversized Backer Rod into the slot between the Base Frame and Pan, on each side of the joint, for the full length of the run. The Backer Rod should be positioned just below the exposed edges of the Base Frame and Pan. **Note:** The Backer Rod is used to prevent dirt and debris from gathering in the slot between the Frame and Pan that could hinder movement or the resting position of the Pan.

9.2 Apply an approved sealant above the backer rod along the full length of the joint to prevent water ingress.

9.3 Fill the remaining blockout area, above the Base Frame anchors, with a quality non-shrink grout (by others).

9.4 In the Pan, place 4" x 4" - W2.9 X W2.9 rebar mesh (by others) along the full length of the run. The rebar mesh should span nearly the full width of the Pan, and should be positioned approximately 3/4" below the top surface of the Pan.

IMPORTANT Note: Select the proper concrete mix: Discuss with your local Concrete supplier Engineer to recommend a concrete for this special application in effort to prevent excessive shrinking, curling, and fracturing of the concrete from occurring. Recommendations include: Low water to cement ratio, #8 coarse aggregate, and/or a 60/40 cement to ash combination, greater full cure time (60 day minimum recommended), and a recommended shrinkage admixture. If concrete is being applied outside, canopies or burlap should be used to minimize excessive differential curing from occurring. Concrete should not be installed if there is the possibilities the temperatures could drop below recommended curing temperatures during the curing cycle.

9.5 Fill the Pan with the selected concrete (concrete by others). Float the concrete level with the exposed edges of the Pan. Smooth and finish as required. Apply misters for moist curing (see Important Note:).

IMPORTANT Note: Measures must be taken to prevent excess shrinking and curling from occurring. Pinnacle Solutions recommends the installer moist cure the concrete for a minimum of 12 days. During the final 5 days reduce duration of moist curing incrementally. These efforts will aid in the reduction of differential curing from occurring causing warping of the concrete and possibly damaging the aluminum pans.

STEP 9 continued

COMPLETING THE INSTALLATION

Included below are links to articles and documentation for additional resources to aid in the reduction of shrinking and warping caused by improperly specified or curing of the concrete.

http://www.cement.org/tech/cct_floors_shrinkage.asp

http://www.irc.nrc-cnrc.gc.ca/ctu_sc_n44

IMPORTANT Note: After all misting and troweling has been completed, apply the recommended water based concrete curing compound (not a cure and seal) (by others) to the entire surface of the concrete.

9.6 When the concrete has set or after any other floor finish work is complete, remove the duct tape from along the exposed surface of the Pan and Base Frames. Before removing the oversized Backer Rod, vacuum off the top surface to remove all loose grout, concrete, dirt and debris that might fall into the slot as the Backer Rods are removed. Then remove the Backer Rods.

9.7 Place new backer rods (by others) and caulking (by others) along the full length of the slots between the Pan and Base Frames. The caulk should be smooth and level with the exposed surfaces of the Frame and Pan. Note: To provide the proper thermal expansion and compression capability, select a caulking that will provide +/-50% movement capability per nominal width. We recommend using **Sika® 2C NS** where available. The caulking should be applied per the manufactures recommendations and width to depth ratio.

THE INSTALLATION SHOULD NOW BE COMPLETE. PROTECT THE INSTALLATION UNTIL FINAL ARCHITECTURAL INSPECTION.